

REVISIONS			
REV.	ECN No	DESCRIPTION	DATE
1		RELEASE TO PRODUCTION	23/08/2018

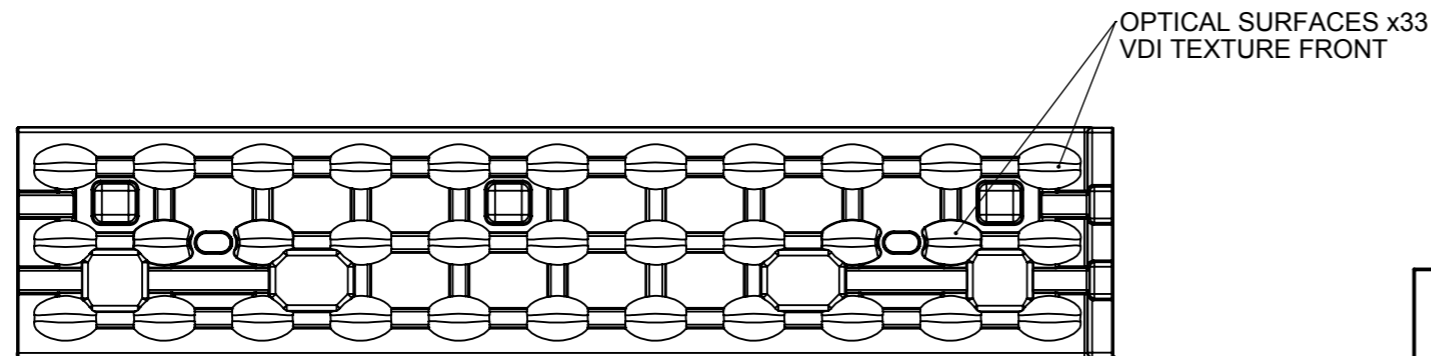
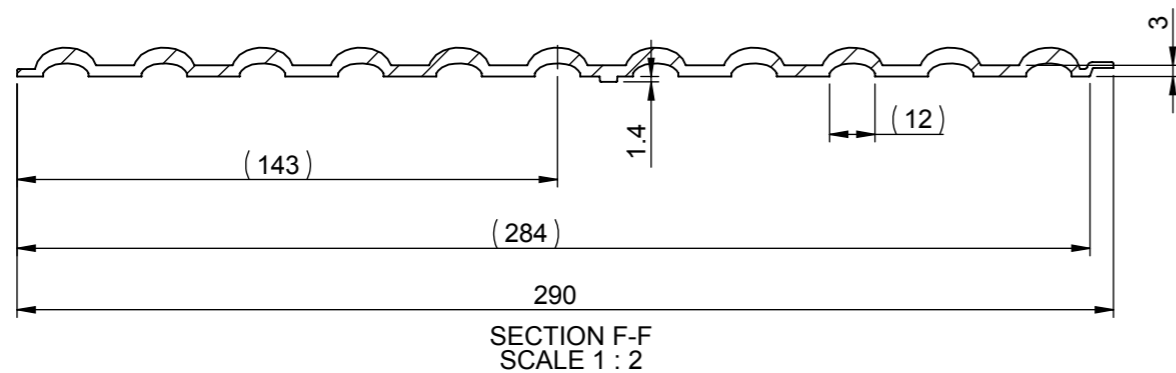
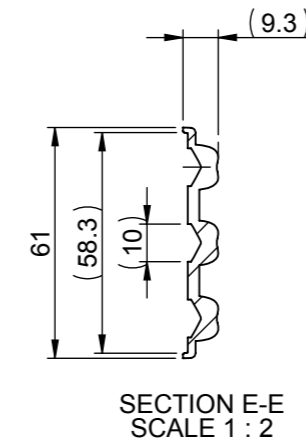
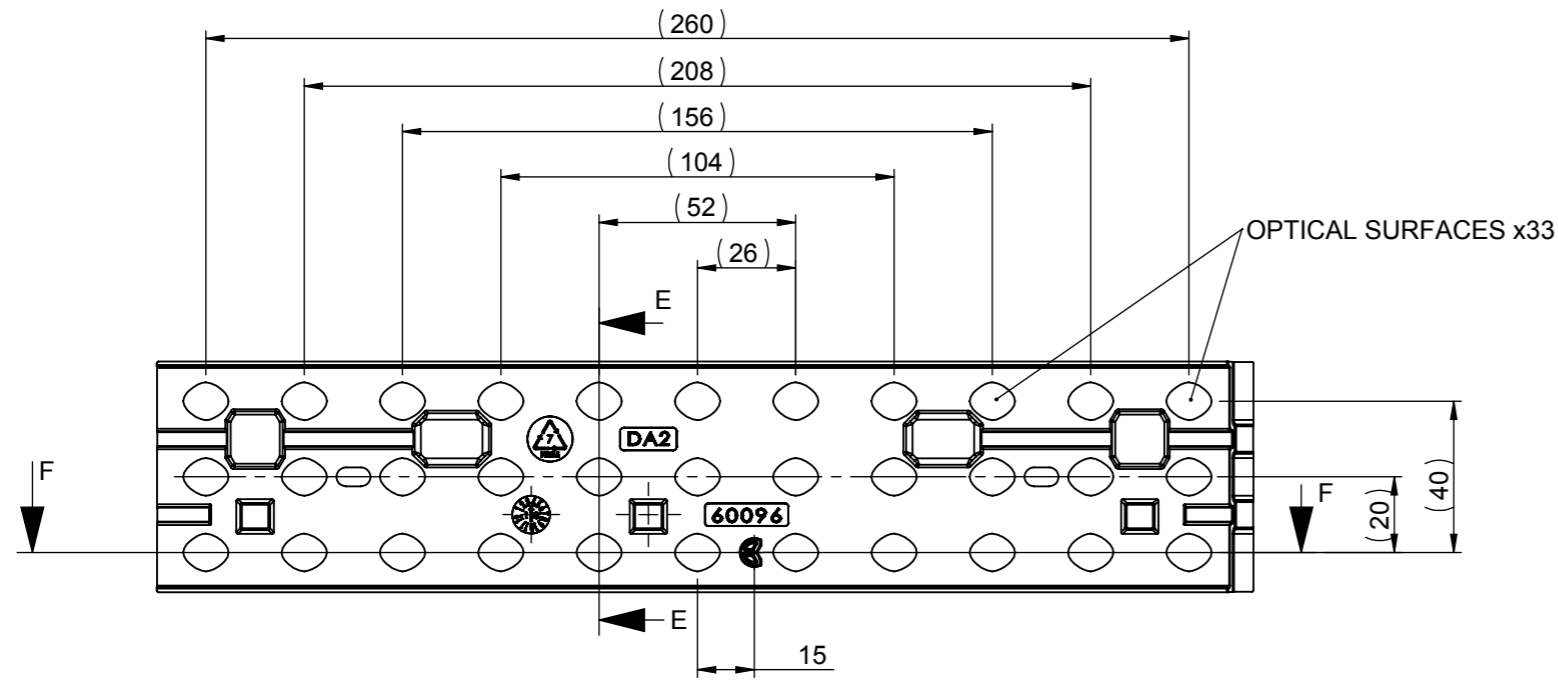

NOTES:

- 1 - MATERIAL: PMMA
- 2 - FINISH: OPTICAL SURFACES ARE OPTICALLY POLISHED TO SPI-A1 OUTER LENS HAS VDI TEXTURE FROST
- 3 - OVERALL PART THICKNESS = SEE 3D FILE
- 4 - GENERAL DRAFT 2°
- 5 - GENERAL FILLET 0.20mm
- 6 - APPROX MASS 65.3 ±0,5 GRAMS
- 7 - AUXILLIARY DIMENSIONS ARE FOR INFORMATION ONLY AND MUST NOT TO BE USED FOR INSPECTION

CUSTOMER DRAWING

SHEET 2 OF 2

<p>Unit 6-7 Faraday Road Rabans Lane Industrial Area, Aylesbury, HP19 8RY, UK. Tel: +44(0) 01753 575 011 sales@carclo-optics.com www.carclo-optics.com</p>		Title		33UP DA2, TRIDONIC, OVERLAP, PMMA	
THIRD ANGLE PROJECTION		GENERAL TOLERANCES UNLESS OTHERWISE STATED DIN16742: TG6	CONFIDENTIAL: UNAUTHORISED COPYING, DISCUSSION & DISTRIBUTION PROHIBITED	DIMENSION IN mm	
		Drawn by M Wells Customer CARCLO Scale 1:2		Format Size A3	
Part N° 60093		Project N° P00481		CAD File 60096_Rev-1_33Up_DA2_Tri_Overlap_PMMA	