

CUSTOMER DRAWING

REVISIONS					
REV.	D.C.N NUMBER	DESCRIPTION	DATE	CHECKED BY DATE	APPROVED BY DATE
D2		FIRST ISSUE	31/07/2013		
1	1367	FIRST PRODUCTION PART	28/01/2014	P.S 29/01/2014	M.H 31/01/2014
2	1442	OPTIC TYPE & CAVITY IDENTS ADDED. PJS	18/09/2015		

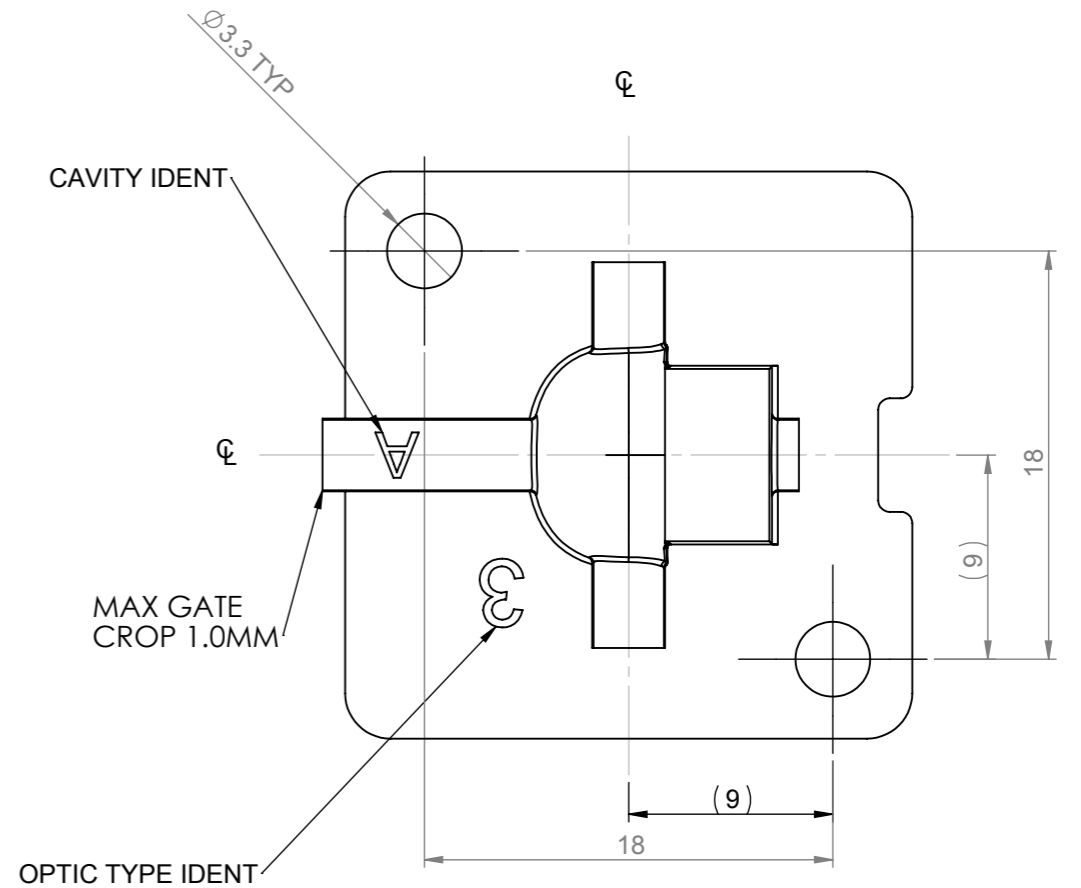
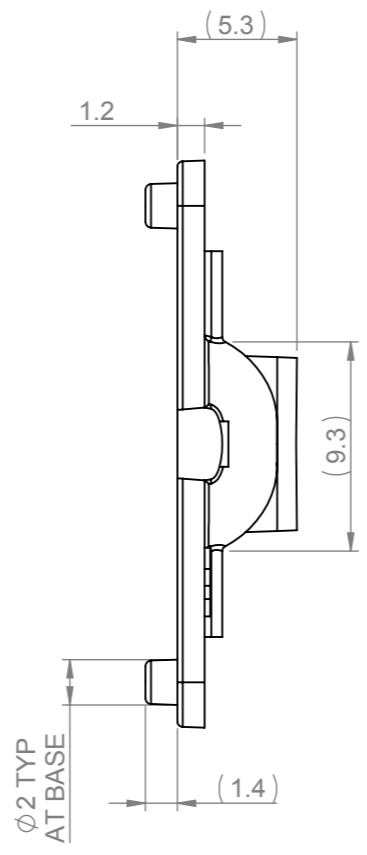
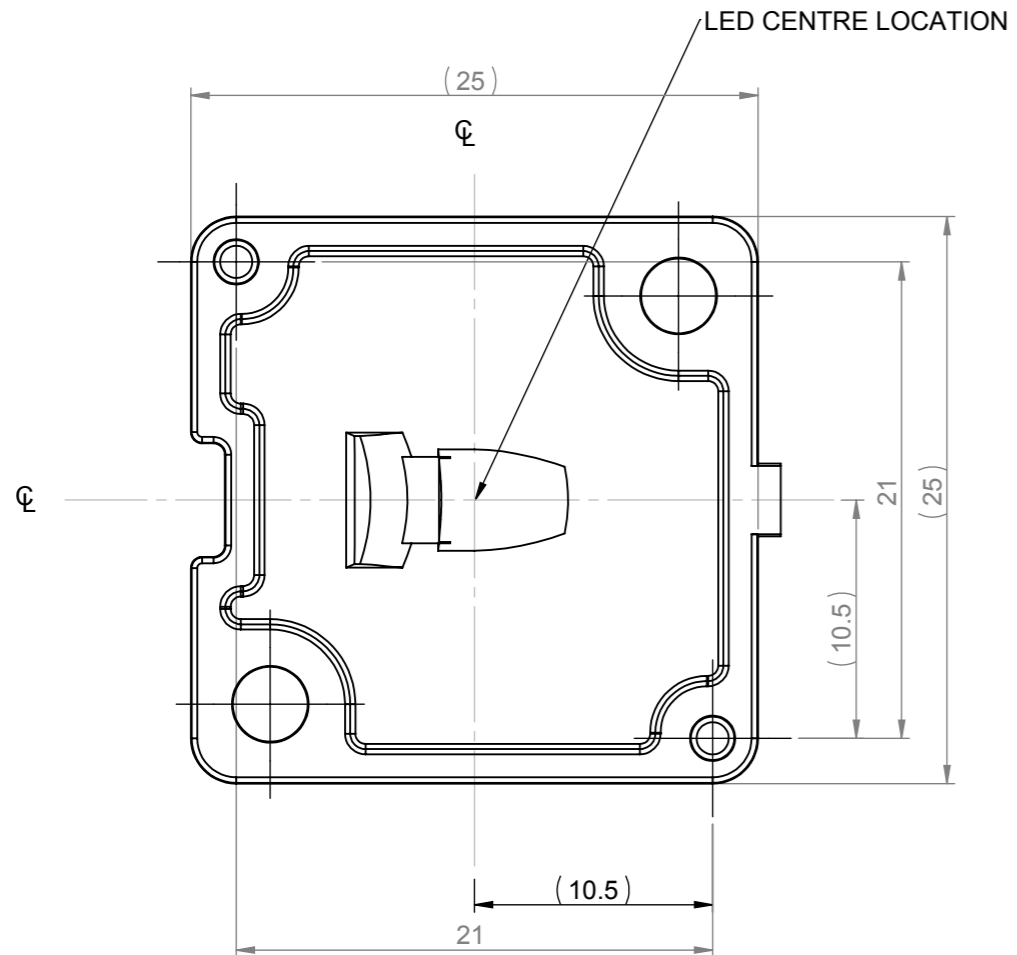

- NOTES:
- 1 - MATERIAL: PMMA
 - 2 - FINISH: OPTICAL SURFACES ARE OPTICALLY POLISHED COMMERCIAL POLISH FOR ALL NON OPTICAL SURFACES.
 - 3 - GENERAL DRAFT 2°
 - 4 - GENERAL FILLET 0.25MM
 - 5- DIMENSIONS IN BRACKETS ARE FOR INFORMATION ONLY AND NOT FOR INSPECTION

SHEET 2 OF 2

<p>103 Buckingham Avenue SL1 4PF, UK. Tel: +44(0) 01753 575011 Fax: +44(0) 01753 811 359 sales@carclo-optics.com www.carclo-optics.com</p>	Title		MINI HUBBLE III SINGLE OPTIC										
	Drawn by	BB	Customer	CARCLO	Scale	AS SPEC							
<p>THIRD ANGLE PROJECTION</p>	GENERAL TOLERANCES UNLESS OTHERWISE STATED		DIMENSION IN mm		Format Size	A3							
	<table border="1"> <tr> <th>LINEAR</th> <th>ANGULAR</th> </tr> <tr> <td>0 ±0.25</td> <td>0 ±1°</td> </tr> <tr> <td>0.0 ±0.1</td> <td>0.0 ±0.5°</td> </tr> <tr> <td>0.00 ±0.05</td> <td>0.00 ±0.1°</td> </tr> </table>		LINEAR	ANGULAR	0 ±0.25	0 ±1°	0.0 ±0.1	0.0 ±0.5°	0.00 ±0.05	0.00 ±0.1°	<p>CARCLO Optics</p> <p>CONFIDENTIAL: UNAUTHORISED COPYING, DISCUSSION & DISTRIBUTION PROHIBITED</p>		CAD File
LINEAR	ANGULAR												
0 ±0.25	0 ±1°												
0.0 ±0.1	0.0 ±0.5°												
0.00 ±0.05	0.00 ±0.1°												
Part N°			12771	Drw N°	70250								