

CUSTOMER DRAWING

REVISIONS					
REV.	D.C.N NUMBER	DESCRIPTION	DATE	CHECKED BY DATE	APPROVED BY DATE
D2		FIRST ISSUE	31/07/2013		
1	1367	FIRST PRODUCTION PART	28/01/2014	P.S. 29/01/2014	MH 31/01/2014
2	1442	OPTIC TYPE IDENT ADDED. P.SUTTON	08/09/2015		

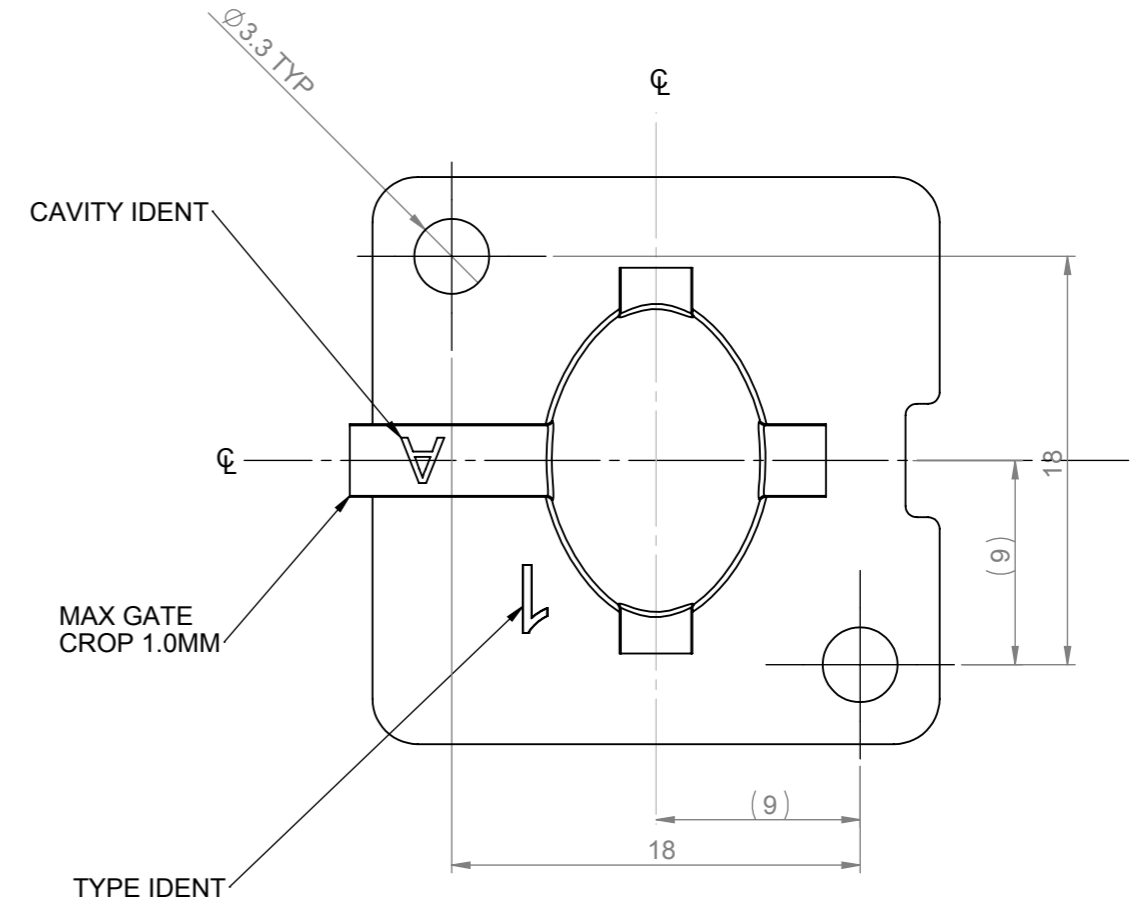
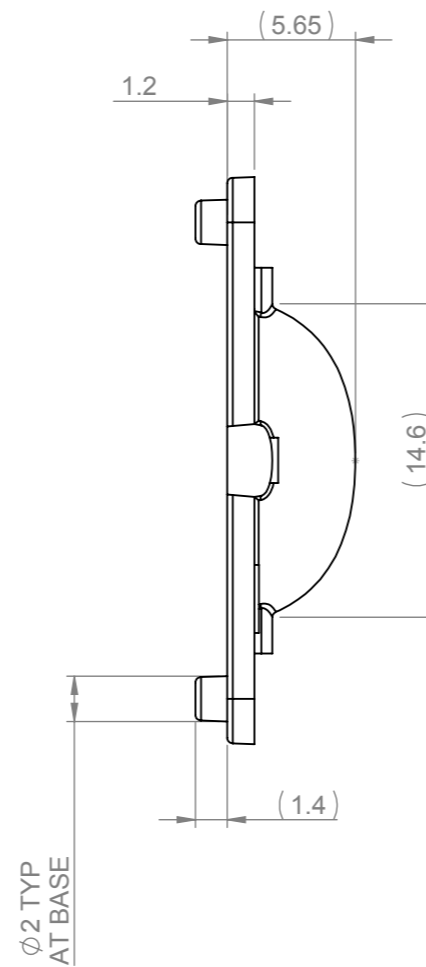
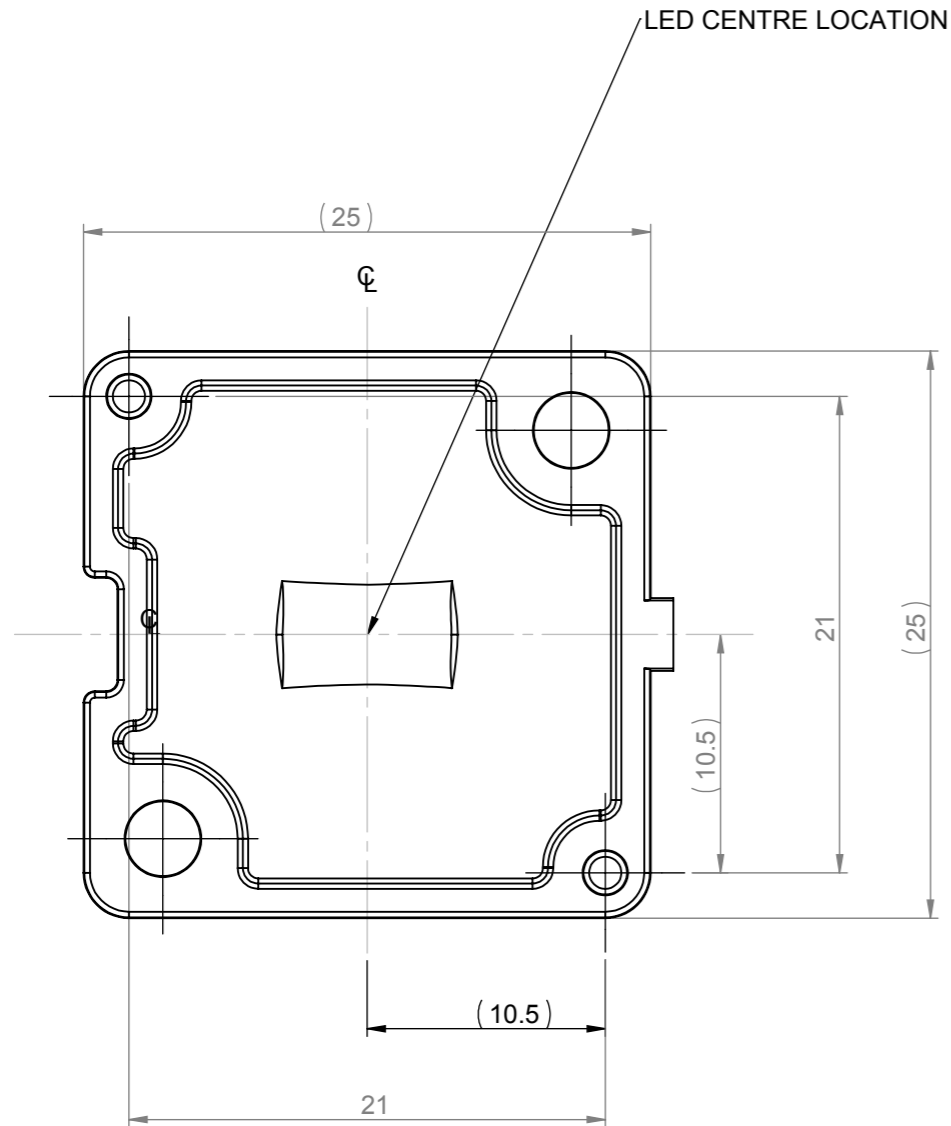

NOTES:

- 1 - MATERIAL: PMMA
- 2 - FINISH: OPTICAL SURFACES ARE OPTICALLY POLISHED COMMERCIAL POLISH FOR ALL NON OPTICAL SURFACES.
- 3 - GENERAL DRAFT 2°
- 4 - GENERAL FILLET 0.25MM
- 5 - DIMENSION IN BRACKETS ARE FOR INFORMATION ONLY AND NOT FOR INSPECTION

SHEET 2 OF 2

<p>103 Buckingham Avenue SL1 4PF, UK. Tel: +44(0) 01753 575 011 Fax: +44(0) 01753 811 359 sales@carclo-optics.com www.carclo-optics.com</p>	Title		MINI HUBBLE I SINGLE OPTIC											
	Drawn by	BB	Customer	CARCLO	Scale	3:1								
<p>THIRD ANGLE PROJECTION</p>	<p>GENERAL TOLERANCES UNLESS OTHERWISE STATED</p> <table border="1"> <tr> <th>LINEAR</th> <th>ANGULAR</th> </tr> <tr> <td>0 ±0.25</td> <td>0 ±1°</td> </tr> <tr> <td>0.0 ±0.1</td> <td>0.0 ±0.5°</td> </tr> <tr> <td>0.00 ±0.05</td> <td>0.00 ±0.1°</td> </tr> </table>		LINEAR	ANGULAR	0 ±0.25	0 ±1°	0.0 ±0.1	0.0 ±0.5°	0.00 ±0.05	0.00 ±0.1°	<p>CARCLO Optics</p> <p>CONFIDENTIAL: UNAUTHORISED COPYING, DISCUSSION & DISTRIBUTION PROHIBITED</p>		<p>DIMENSION IN mm</p> <p>Format Size A3</p>	
LINEAR	ANGULAR													
0 ±0.25	0 ±1°													
0.0 ±0.1	0.0 ±0.5°													
0.00 ±0.05	0.00 ±0.1°													
CAD File		12763_70248_Rev-2		Part N°		12763								
Drw N°		70248		Drw N°		70248								