

REVISIONS			
REV.	ECN No	DESCRIPTION	DATE
D3	1381	TRANSFERED TO PRODUCTION P.SUTTON	23/09/2014
1	1607	RELEASE FOR PRODUCTION. M.WELLS	27/2/2020

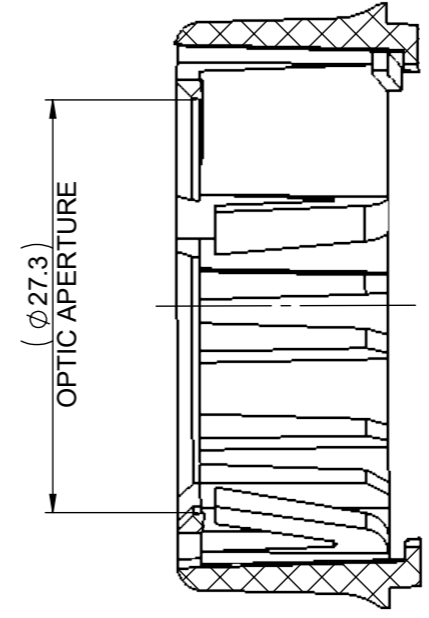

SECTION A-A

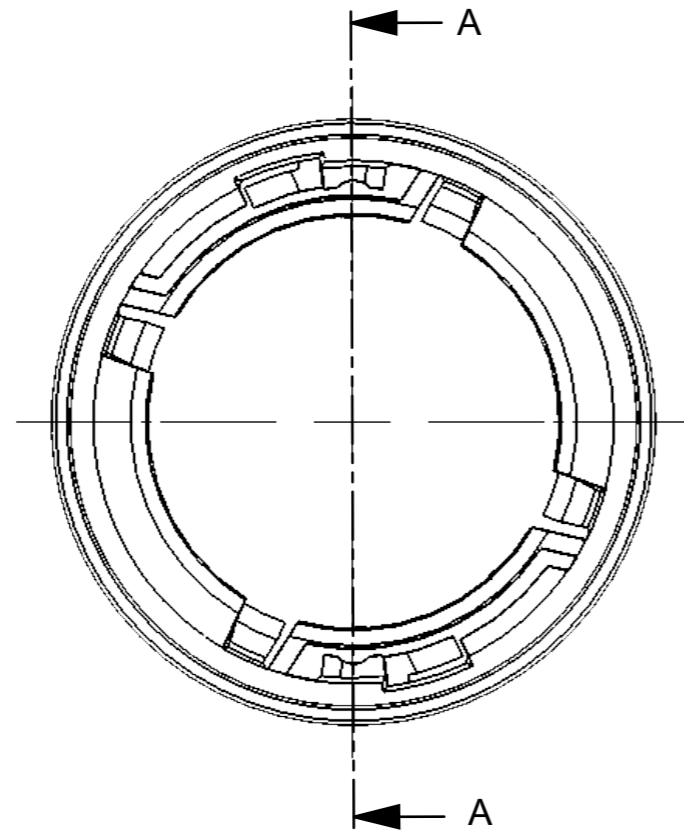
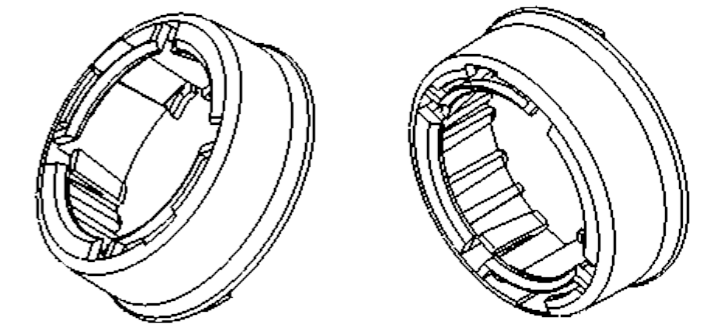
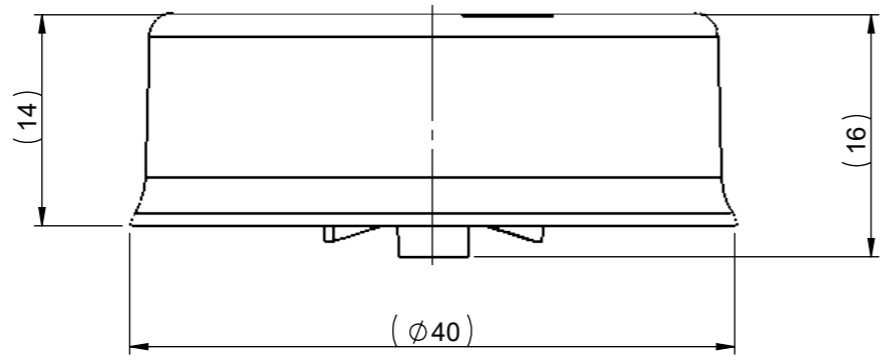

SCALE 1:1

- NOTES:
- 1 - MATERIALS: POLYCARBONATE BLACK
 - 2 - FINISH: EXTERNAL SURFACE TEXTURED VDI20
 - 3 - COMPATIBLE WITH BJB 47.319.6XXX Ø40mm COB CONNECTORS
 - 4 - APPROX WEIGHT 4.0 GRAMS
 - 5 - CRITICAL TO QUALITY DIMENSIONS (X.XX) ARE FOR INSPECTION
THEORETICALLY EXACT DIMENSIONS [X.XX] TO ISO 1101
AUXILIARY DIMENSIONS (X.XX) ARE FOR INFORMATION ONLY

CUSTOMER DRAWING

SHEET 2 OF 2

 Unit 6-7 Faraday Road Rabans Lane Industrial Area, Aylesbury, HP19 8RY, UK. Tel: +44(0) 01753 575 011 sales@carclo-optics.com www.carclo-optics.com	Title		HOLDER, 30MM, BJB MOUNTING BASE			
	Drawn by	P.SUTTON	Customer	Carclo	Scale	2:1
 GENERAL TOLERANCES UNLESS OTHERWISE STATED DIN16742: TG6	CARCLO Optics CONFIDENTIAL: UNAUTHORISED COPYING, DISCUSSION & DISTRIBUTION PROHIBITED		DIMENSION IN mm		Format Size	A3
	CAD File	12875 Rev1		Part N°	12875	Project N°