

REVISIONS			
REV.	ECN No	DESCRIPTION	DATE
2		RELEASED TO PRODUCTION. M WELLS	11/03/2022

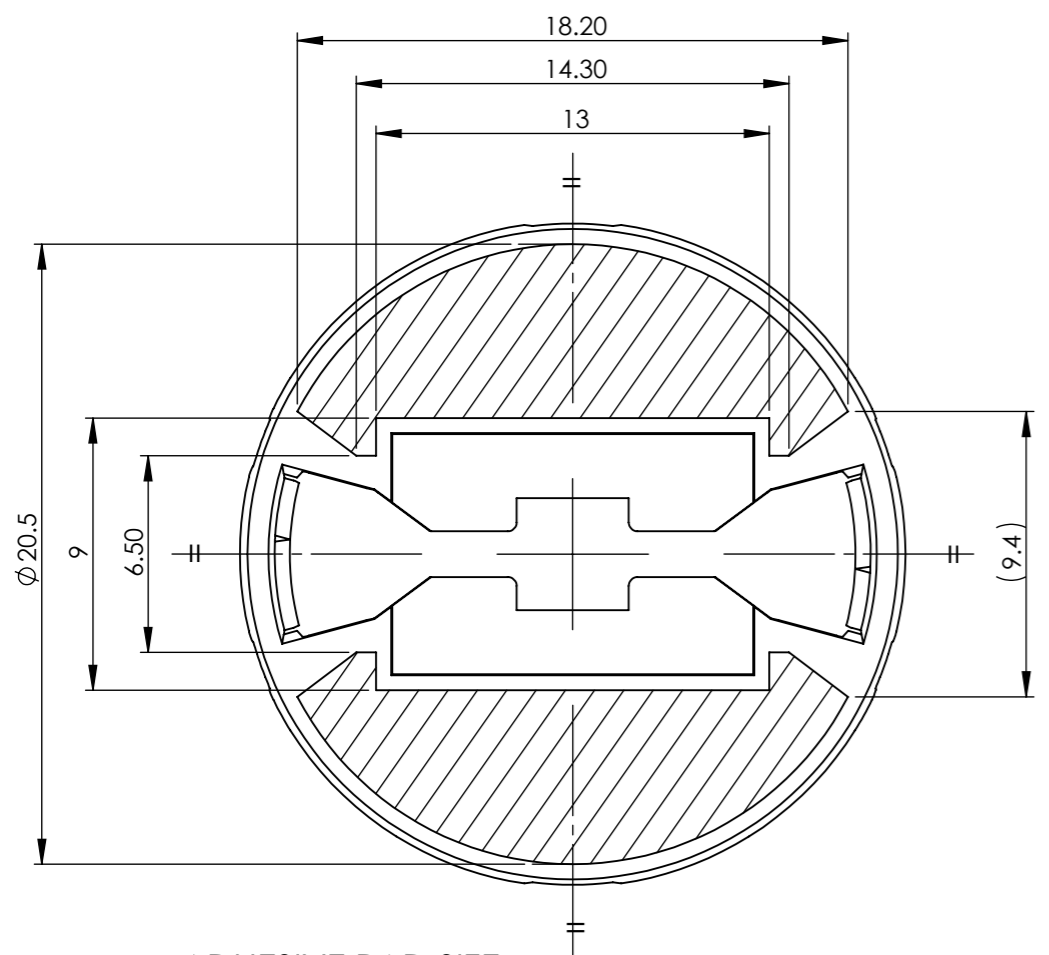

ADHESIVE PAD SIZE

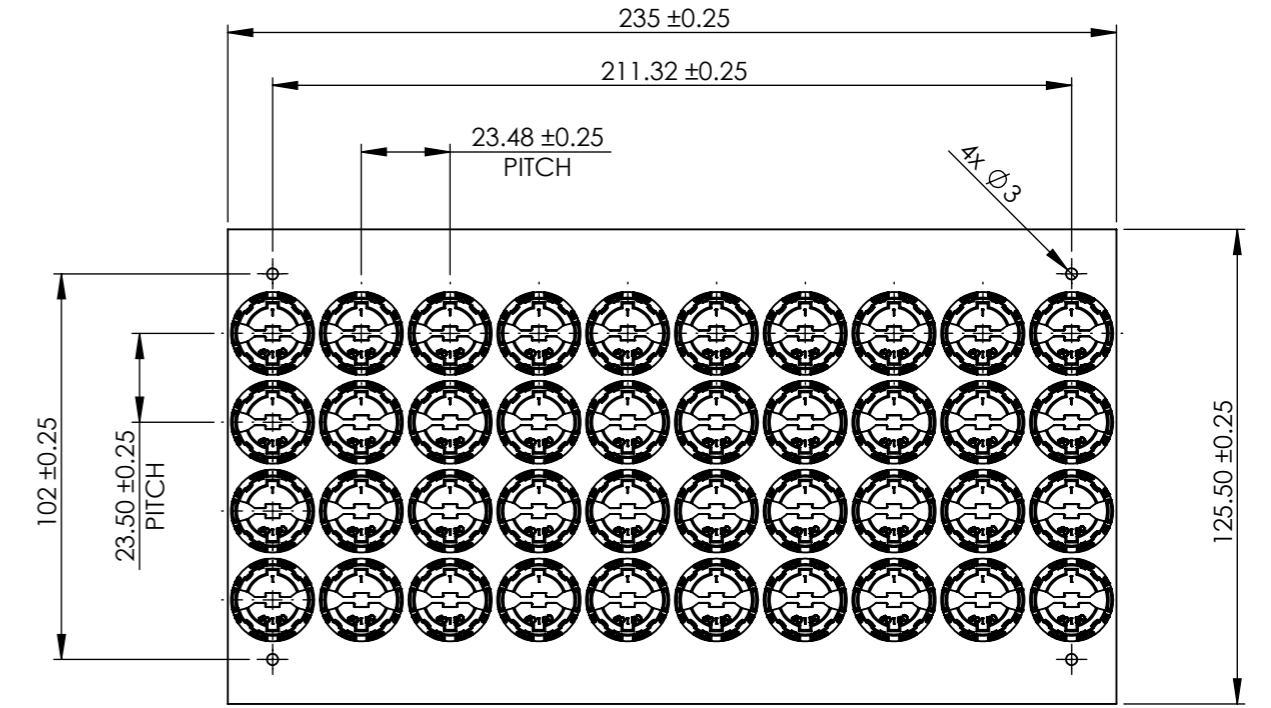

HOLDER LAYOUT 4x10 ON ADHESIVE TAPED SHEET
SCALE 1:2

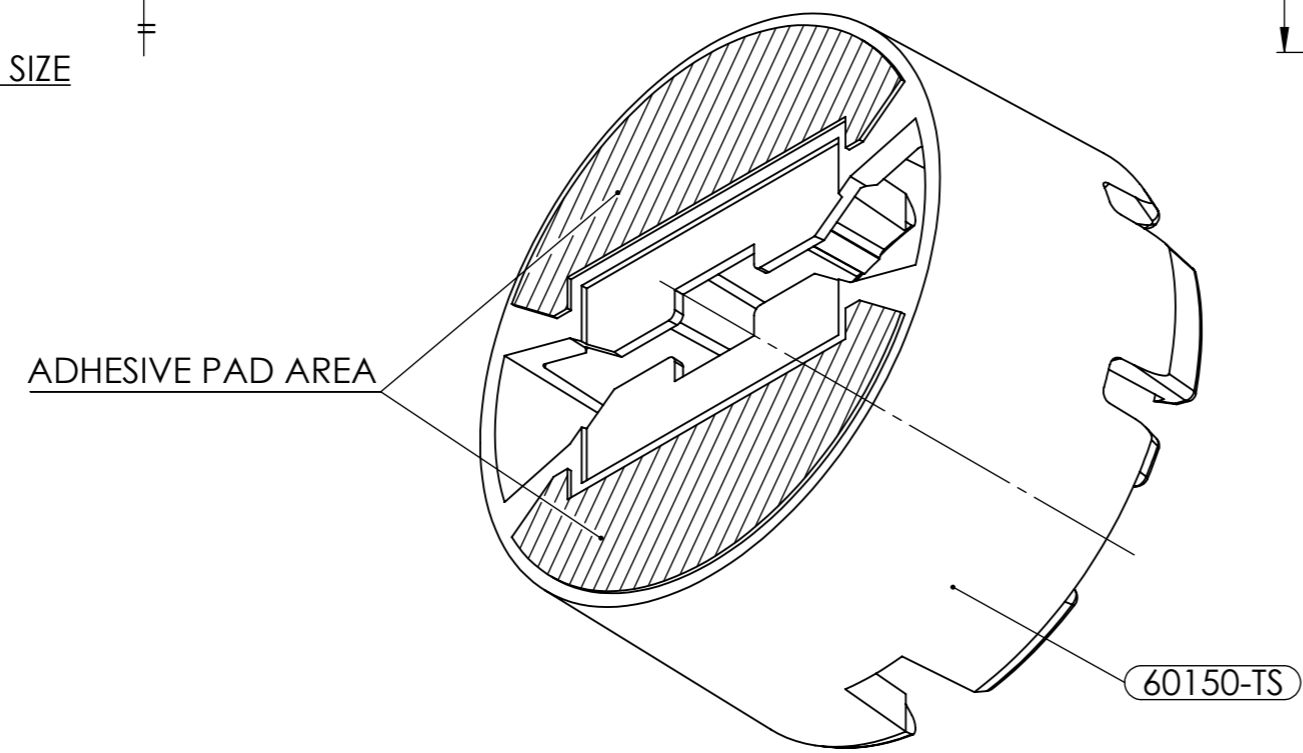

NOTES:

- 1 - MATERIALS: ADHESIVE PAD SPEC, 3M 9495LE, 0.17mm THICK
- 2 - HOLDERS SUPPLIED IN 4x10 LAYOUT ON TAPED SHEETS
- 3 - GENERAL ADHESIVE PAD POSITION 0.2mm FROM HOLDER EDGE
- 4 - FOR ALL OTHER DIMENSIONS SEE 3D CAD FILE / HOLDER DRAWING 60150
- 5 - CRITICAL TO QUALITY DIMENSIONS (X.XX) ARE FOR INSPECTION
THEORETICALLY EXACT DIMENSIONS [X.XX] TO ISO 1101
AUXILIARY DIMENSIONS (X.XX) ARE FOR INFORMATION ONLY

SHEET 1 OF 1

 Unit 6-7 Faraday Road Rabans Lane Industrial Area, Aylesbury, HP19 8RY, UK. Tel: +44(0) 01753 575 011 sales@carclo-optics.com www.carclo-optics.com	Title		HOLDER OH11.6, ø20mm OPTIC (3.5 x 3.5mm LED) TAPED SHEET			
	Drawn by	M WELLS	Customer	CARCLO	Scale	4:1
 GENERAL TOLERANCES UNLESS OTHERWISE STATED ISO 2768-m	CARCLO Optics CONFIDENTIAL: UNAUTHORISED COPYING, DISCUSSION & DISTRIBUTION PROHIBITED		DIMENSION IN mm		Format Size	A3
	CAD File	60150 Rev2 Holder		Part N°	60150-TS	Project N°