

REVISIONS			
REV.	ECN No	DESCRIPTION	DATE
2		RELEASED PRODUCT. M.WELLS	11/03/2022

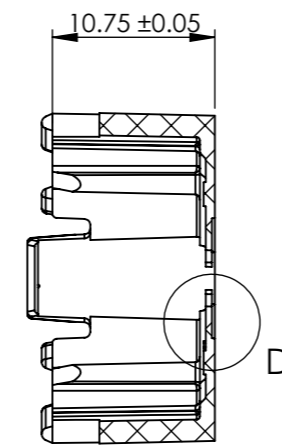

SECTION B-B

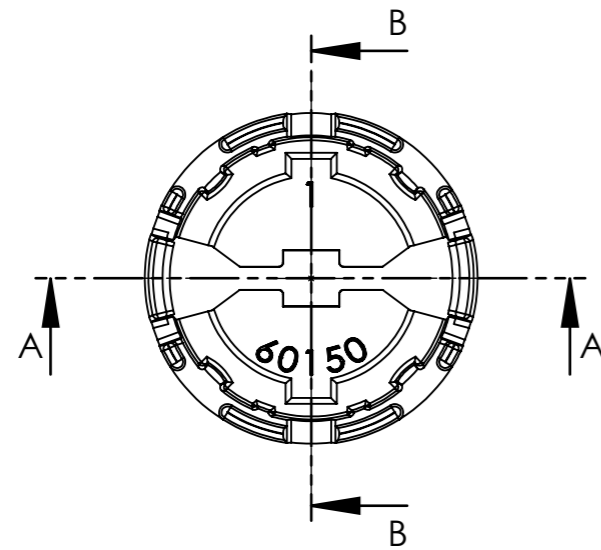
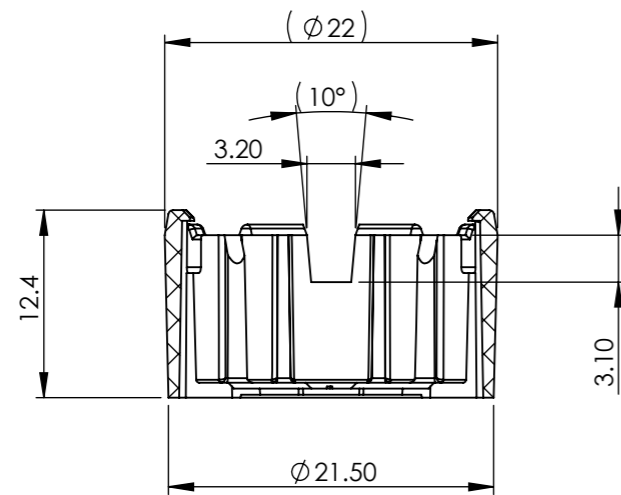
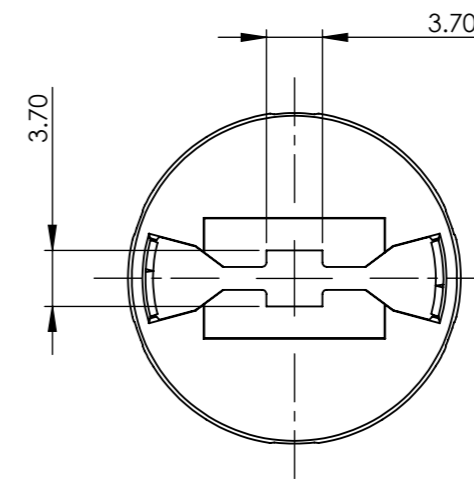

SECTION A-A

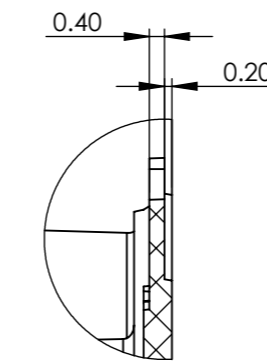

DETAIL D  
SCALE 5 : 1

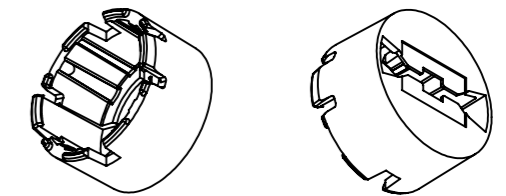

PART VIEW  
SCALE 1:1

NOTES:

- 1 - MATERIAL: POLYCARBONATE, BLACK
- 2 - FOR ALL OTHER DIMENSIONS SEE 3D CAD FILE.
- 3 - PART WEIGHT 1.34 ± 10% GRAMS
- 4 - CRITICAL TO QUALITY DIMENSIONS (X.XX) ARE FOR INSPECTION THEORETICALLY EXACT DIMENSIONS [X.XX] TO ISO 1101 AUXILIARY DIMENSIONS (X.XX) ARE FOR INFORMATION ONLY

CUSTOMER DRAWING

SHEET 2 OF 2

 Unit 6-7 Faraday Road Rabans Lane Industrial Area, Aylesbury, HP19 8RY, UK. Tel: +44(0) 01753 575 011 sales@carclo-optics.com www.carclo-optics.com	Title		HOLDER OH11.6, $\phi 20$ mm OPTIC (3.5 x 3.5mm LED)			
	Drawn by	M WELLS	Customer	CARCLO	Scale	2:1
THIRD ANGLE PROJECTION	GENERAL TOLERANCES UNLESS OTHERWISE STATED DIN16742:TG6		DIMENSION IN mm		Format Size	A3
 CARCLO Optics CONFIDENTIAL: UNAUTHORISED COPYING, DISCUSSION & DISTRIBUTION PROHIBITED	CAD File		60150 Rev2 Holder		Part N°	
	60150		Project N°		P00882	