

REVISIONS			
REV.	ECN No	DESCRIPTION	DATE
2	1616	RELEASED PRODUCT. M.WELLS	11/03/2022

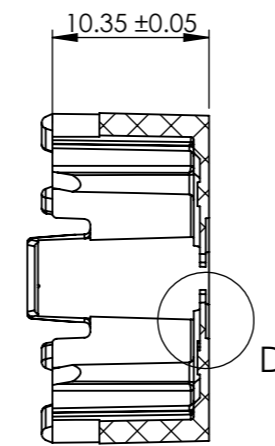

SECTION B-B

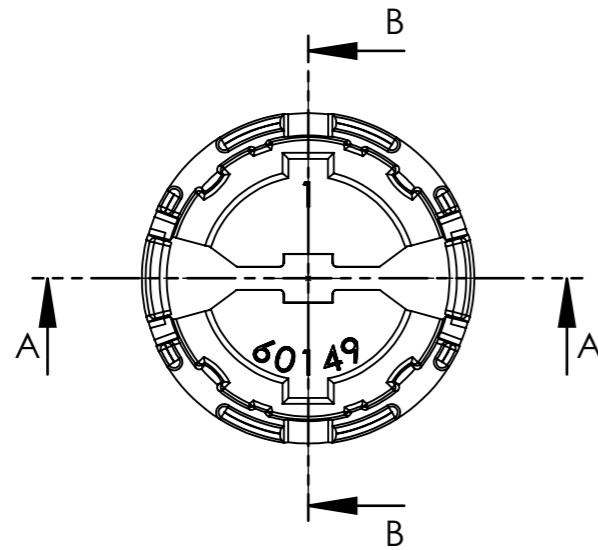
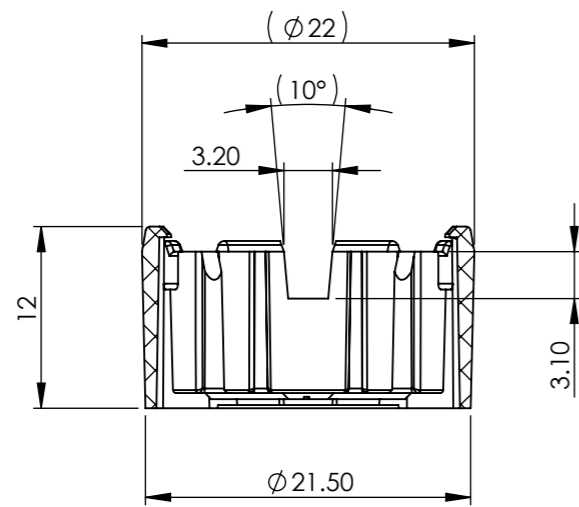
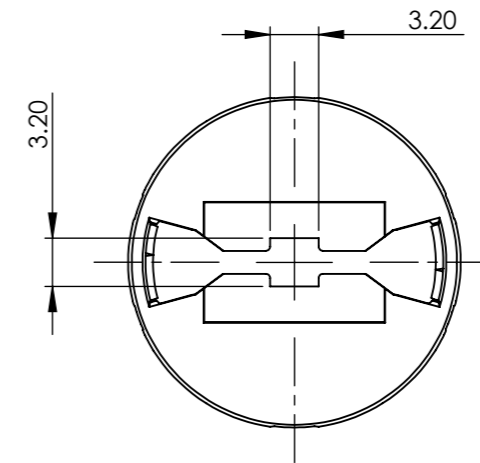

SECTION A-A

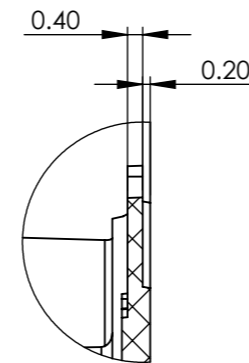

DETAIL D
SCALE 5 : 1

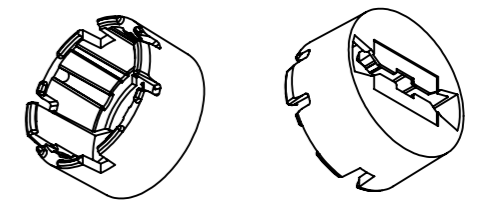

PART VIEW
SCALE 1:1

NOTES:

- 1 - MATERIAL: POLYCARBONATE, BLACK
- 2 - FOR ALL OTHER DIMENSIONS SEE 3D CAD FILE.
- 3 - PART WEIGHT 1.29 ± 10% GRAMS
- 4 - CRITICAL TO QUALITY DIMENSIONS (X.XX) ARE FOR INSPECTION THEORETICALLY EXACT DIMENSIONS (X.XX) TO ISO 1101 AUXILIARY DIMENSIONS (X.XX) ARE FOR INFORMATION ONLY

CUSTOMER DRAWING

SHEET 2 OF 2

<p>Unit 6-7 Faraday Road Rabans Lane Industrial Area, Aylesbury, HP19 8RY, UK. Tel: +44(0) 01753 575 011 sales@carclo-optics.com www.carclo-optics.com</p>	Title		HOLDER OH11.2, ø20mm OPTIC (3.0 x 3.0mm LED)			
	Drawn by	M WELLS	Customer	CARCLO	Scale	2:1
THIRD ANGLE PROJECTION	GENERAL TOLERANCES UNLESS OTHERWISE STATED DIN16742:TG6		DIMENSION IN mm		Format Size	A3
	CARCLO Optics CONFIDENTIAL: UNAUTHORISED COPYING, DISCUSSION & DISTRIBUTION PROHIBITED		CAD File	60149 Rev2 Holder		
	Part N°	60149		Project N°	P00882	