

©2008 CARCLO
ALL DIMENSIONS IN mm

CUSTOMER DRAWING

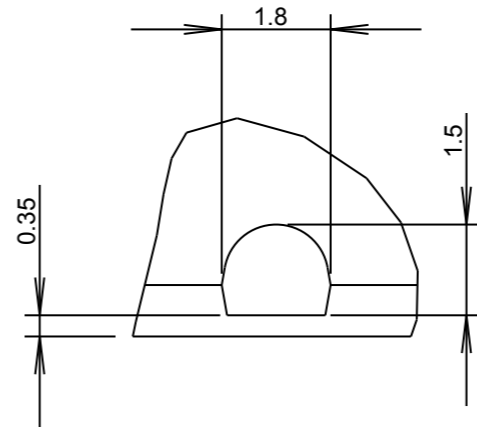

DETAIL B
SCALE 8:1

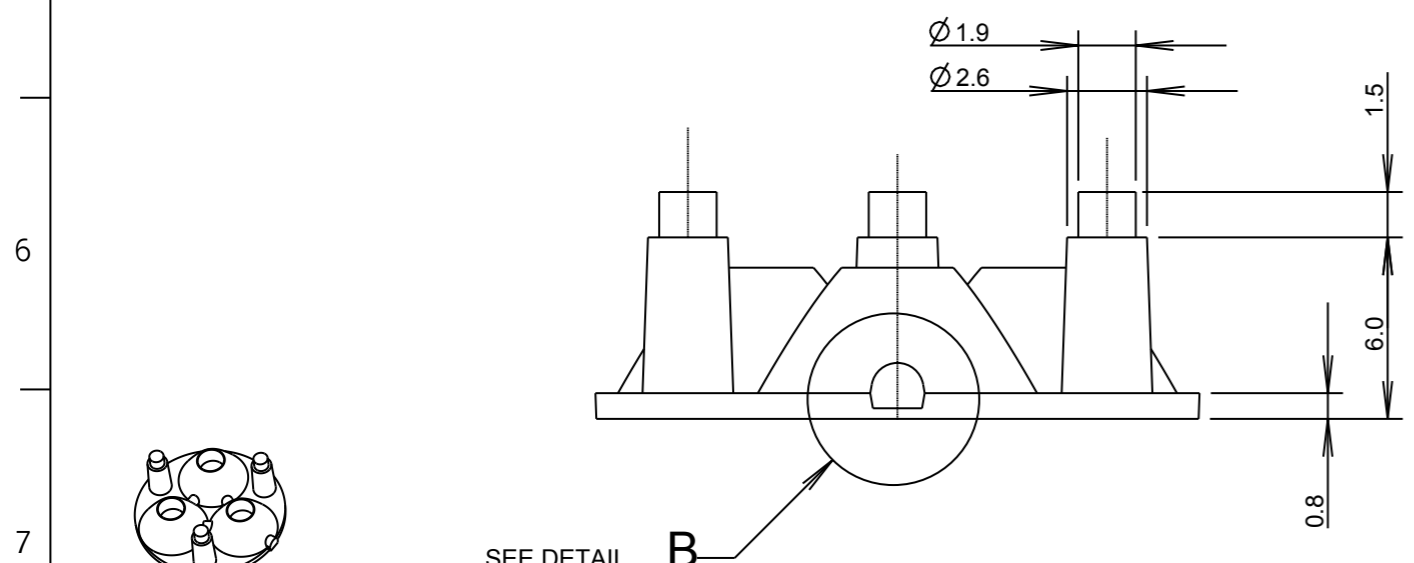

SCALE 1:1

MATERIAL - UV STABILISED CLEAR POLYCARBONATE

ISS.	DATE	E.C.N.	DESCRIPTION
1	06-May-08		FIRST ISSUE
2	18-Jun-08		GATE SIZE INCREASED
3	12-Nov-08	10/08/1233	LEG PIN LENGTH REDUCED TO 15MM



CARCLO TECHNICAL PLASTICS (SLOUGH)
111 BUCKINGHAM AVE, SLOUGH
SL1 4PF, ENGLAND
TEL: +44 1753 575011 FAX: +44 1753 811359
email: design@carclo-optics.com

GENERAL TOLERANCES (UNLESS STATED)

LINEAR	ANGULAR
X +/- 0.25	X +/- 1°
X.X +/- 0.1	X.X +/- 0.5°
X.XX +/- 0.05	X.XX +/- 0.1°

CUSTOMER

CARCLO

TITLE

10mm TRIPLE OPTIC
NARROW FROSTED

DRAWN

M.K.

DATE

06-May-08

CHK'D

DATE

APP'D

DATE

SCALE

4:1

CARCLO PART No.

10511

SIZE

A3

CARCLO DRG. No.

60528

SHEET

1 OF 2

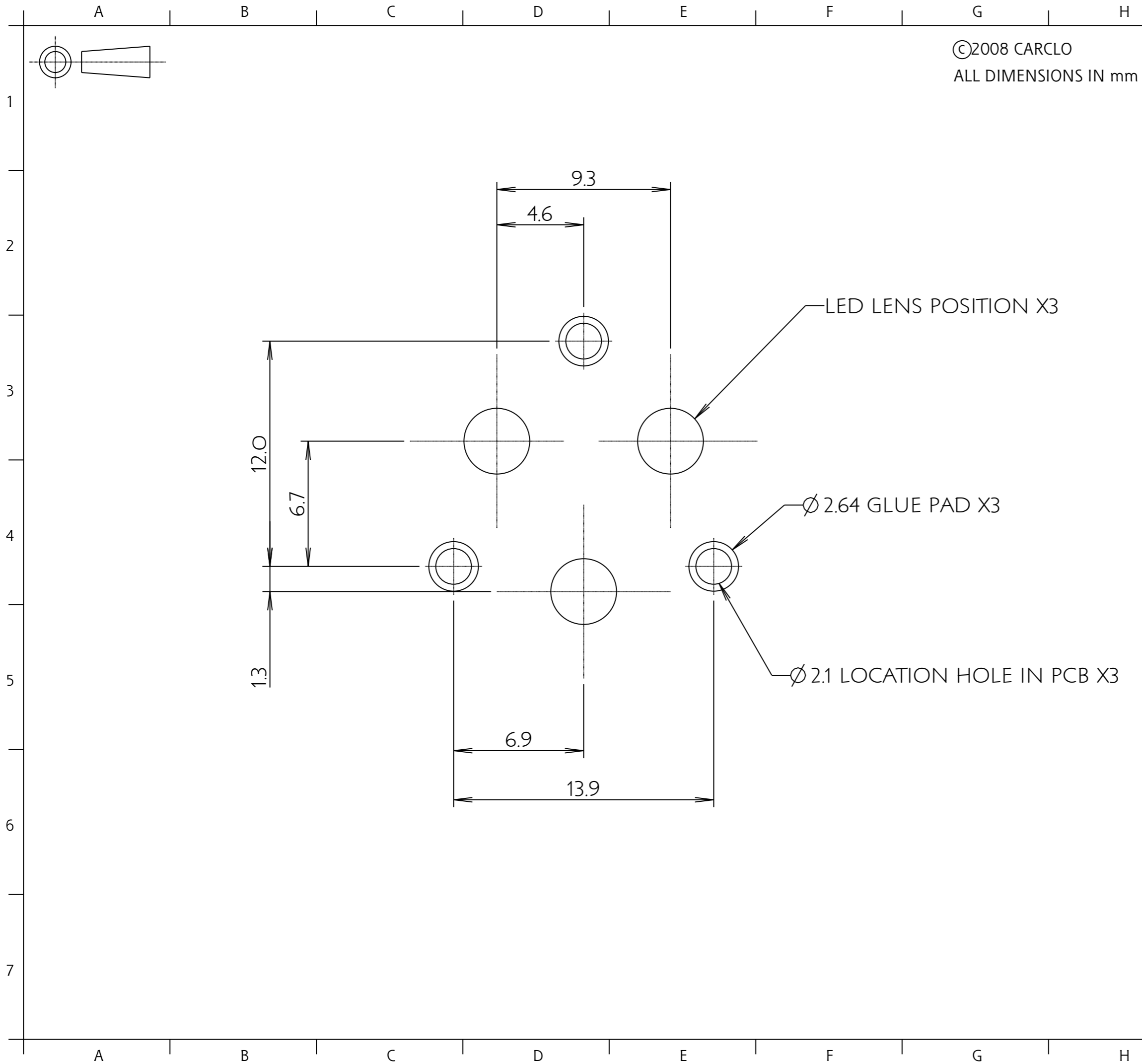

©2008 CARCLO
ALL DIMENSIONS IN mm

ISS.	DATE	E.C.N.	DESCRIPTION
1	06-May-08		FIRST ISSUE
2	18-Jun-08		GATE SIZE INCREASED
3	12-Nov-08	10/08/1233	LEG PIN LENGTH REDUCED TO 15MM

 technical plastics
CARCLO TECHNICAL PLASTICS (SLOUGH)
 111 BUCKINGHAM AVE, SLOUGH
 SL1 4PF, ENGLAND
 TEL: +44 1753 575011 FAX: +44 1753 811359
 email: design@carclo-optics.com

GENERAL TOLERANCES (UNLESS STATED)

LINEAR		ANGULAR	
X	+/- 0.25	X	+/- 1°
X.X	+/- 0.1	X.X	+/- 0.5°
X.XX	+/- 0.05	X.XX	+/- 0.1°

CUSTOMER	CARCLO
----------	--------

TITLE	10mm TRIPLE OPTIC NARROW FROSTED
-------	-------------------------------------

DRAWN	M.K.	DATE	06-May-08
-------	------	------	-----------

CHK'D		DATE	
-------	--	------	--

APP'D		DATE	
-------	--	------	--

SCALE	5:1	CARCLO PART No.	10511
-------	-----	-----------------	-------

SIZE	A3	CARCLO DRG. No.	60528	SHEET	2 OF 2
------	----	-----------------	-------	-------	--------